



Recommendations please read this manual carefully before installing and using the camera. Be sure to keep the manual handy for later reference!

Manual for Model as below  
CCCA-HIXXXX and CCCA-HEXXXX series

# Intellectual High Speed Dome Camera Instruction Manual

## 1. Introduction

This series of high speed dome camera is a new generation products of comprehensive high-tech achievements in surveillance system. The products used throughout the digital control, programming flexibility, simple design precision, the use of sophisticated electrical, rapid sensitive, accurate positioning and smooth operation, automatically adapt to changes in environmental light and shade and objectives near or far. Large-capacity presets storage may set up a number of scanning tour groups, with four sectors automatic positioning tracking ability. With power off memory function automatically restores former state to achieve a real sense of all-round, all-weather, high-reliability, high clarity and intelligence surveillance.

In order to adapt various environmental installations, you can choose wall mounting, suspension mounting & in-ceiling installation. This applies to all products of large areas, target surveillance activities, such as smart buildings, banking security, schools observed the exams, urban roads, the electricity sector, airports and stations monitoring.

- ▣ Simple operation with high-tech: high-tech, entire metal structure, smart design, precise combination & simple operation.
- ▣ Simple installation may interact: it opened the lower cover, not discard the overall housing. Interact with various sectors warning to automatic positioning tracking.
- ▣ Operation stability & nicety: the use of the latest DSP algorithms, sophisticated electrical driven to rapid start & braking smoothly; Positioning accuracy.
- ▣ Low consumption more options: full load (including Sony cameras) peak current of 800 mA, embedded multiple camera agreements options.

## 2. Technical Indicators

### 1) High Speed Dome Camera Technical Parameters

Input Voltage	DC12V±5%
---------------	----------

Power Consumption	9W
Communication protocol	RS485 Bus
Baud Ratio	1200/2400/4800/9600 optional
Pan Rotation Speed	0.4°-360° per second (1-64 class variable speed)
Pan Rotation Range	360° Unlimited Rotation
Tilt Rotation Speed	0.4°-270° per second (1-64 class variable speed)
Tilt Rotation Range	0°-90°
Automatic Reverse Function	Automatically turn 180° as vertical 90°
Zoom Speed Automatic Control	PTZ control speed automatic adjustment based on the focal length
2 Positions Scanning	Arbitrarily Setup
2 Positions Scanning Speed	1-64 class may setup
Preset Position Quantity	100 preset positions, 8 scanning tour groups
Preset Positions Call Speed	1-64 class may setup, 0.4°-360° per second
Scanning Position Stay Time	1-60 second may setup
Scanning Tour Group Capacity	2-64 scanning tour positions may setup randomly
Quantity of Alarm Input Terminals	4 PCS
Alarm Relays Output (Often Shut)	1 PCS ( break apart conditions: power off or detected invasion )
Fans & Heater (Optional)	Fans & Heater automatically activated AC220V/AC24V ( Optional )
Environmental Temperature	Indoor ( 0°C-4°C); Outdoor ( -40°C-60°C )
Environmental Humidity	≤95% no frost phenomenon

**2) High Speed Dome Camera Lens Parameters (for example embedded Sony integrative camera)**

Model	SONY 18X Optical Zoom Color / SONY 18X Optical Zoom (Day/Night)
Synchronization	internal synchronization/ external synchronization
Scanning System	2:1 interlace
Horizontal Resolution	More than 480 TVL
Minimum Illumination	0.7Lux/0.002Lux
Aperture	Automatic/Manual
Focus	Automatic/Manual
Zoom Rate	18X Optical Zoom
Focal Length	4.1/73.8mm
Angle of View	47°(Wide), 2°(Tele)°
Backlight Compensation	On/Off switch able
White Balance	Automatic
Gain Control	Automatic
Signal Format	NTSC/PAL

Luminance S/N	More than 55dB
Video Output	1.0±0.2Vpp

### 3. Switch Setting

Before installation Please confirm the mainframe use the communications protocol, baud ratio & camera ID fully consistent with the control system. The corresponding switch position and wiring are as below:



#### 1) Camera ID Setting

The high speed dome camera required setting ID before using. The ID set by the 8-digital ID setup switch (SW1) on PCB, 8421 code used binary system. ID setup range: 00000000-11111111, which the ID 11111111 is broadcasting code. Digital 1 means switch ON, and digital 0 means OFF, for



example:

This ID setup switch means 10010011, corresponding ID 148. Another setup switch SW2 is similar to SW1. Digital 1 means ON and digital 0 means off. Each camera ID setting and OSD like as below:

Camera ID Communication Address Code OSD Keyboard CAM Selection

00000000	00H	001	CAM-001
00000001	01H	002	CAM-002
00000010	02H	003	CAM-003
.....			
11111110	0FEH	255	CAM-255

As figure shows The #1 camera all allocated codes switches below (in OFF state), the control keyboard input digital keys [1] and click the [CAM] keys, then keyboard selected #1 camera; #1 camera images show characters "001". Other ID can be setup according to Address Code Correspondence Tables of this manual.

#### 2) Communication Protocol & Baud Ratio Setting

The #3 & #4 positions of SW2 on PCB are used for setting communication protocol, and #5 & #6 positions are used for setting baud ratio, operations like as below:

Switch Position	Communication Protocol	Switch Position	Baud Ratio
3、 4 OFF-----	State Standard Protocol	5、 6 OFF -----	1200BPS
3-OFF、 4-ON-----	PELCO-D	5-OFF、 6-ON-----	2400BPS
3-ON、 4-OFF-----	PELCO-P	5-ON、 6-OFF-----	4800BPS
3-ON、 4-ON-----	Setting by User	5-ON、 6-ON-----	9600BPS

### 3) Camera Selection :

The #7 & #8 positions of SW2 on PCB are used for camera selection.

If the camera had been installed, please don't trigger the #7 & #8 positions of SW2. If not yet installed camera, please install according to the following flow:

- ▣ Use four screws M2-4 fixed the camera to the camera holder make the rotation axis in the middle of the camera downward moves to spacing switch and install transparent cover. The distance from lens to cover should more than 1 cm.
- ▣ Pull out camera lock parts of 9 PIN socket about 2mm , insert 9 PIN flat cables and lock flat cable.
- ▣ Setting #7 & #8 positions of SW2 according to the camera, setting as below table :

#7 position	#8 position	Camera Model
OFF	OFF	SONY Camera
OFF	ON	CNB Camera
ON	OFF	HITACHI Camera
ON	ON	LG Camera

## 4. Wiring

### 1. Wiring Terminals:

- ▣ BNC Video Interface---- Connect with the video cables layout completed.
- ▣ Power Terminal -----Supply voltage **DC12V** , through AC220V-DC12V or AC24-DC12V adaptor connect with the power cable layout completed. **Please attention and confirm the supply voltage meet the requirements of dome camera. Please use AC220V-DC12V or AC24V-DC12V adaptor supplied with the machine.**
- ▣ RS485 Control Terminal---Connect with the control cable layout completed. The positive & cathode polarity of RS485 control cable can not be contrary.
- ▣ Alarm Input Terminal--- 4 terminals connect with the four switches of alarm detector.

Alarm Output Relay Terminal---Connected to the alarm controller or other equipments.

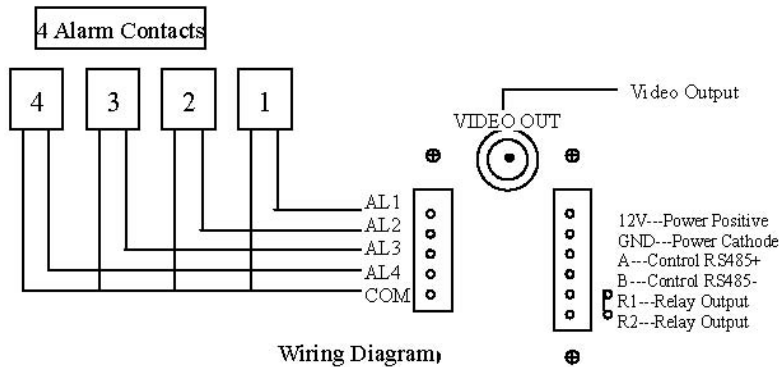

## 5. Alarm Connecting / Setting

This product has four alarm input terminals: AL1, AL2, AL3 & AL4 , corresponding linkage to the preset positions followed by #1, #2, #3 & #4 of the dome camera.

1) Defense Area Alarm Connecting Refer to the [Wiring Diagram]; connect with alarm or other detector to the relative terminals unused channels without connecting.

2) Defense Layout The #1 position of SW2 on PCB is used for alarm setting like as follows :

Switch Position

#1 Position OFF---Often defense, the dome camera implements the acquiesced alarm procedure.

#1 Position ON—May defense or cancel defense. The dome camera implements the defense layout or cancels defense or linkage procedure setup by controller (keyboard).

**a. Often Defense** Switch to the position“OFF” , make the defense area in alarm state for 24 hours. The dome camera running the linkage procedure immediately once this defense area inspect invasion:

- ☞ Move speedy to the corresponding preset positions. When more than two defense areas alarm at the same time, the dome camera will tour scanning these alarm preset positions. The tour scanning will be stopped two minutes later.
- ☞ Alarm output relay cut off, and closed automatically two minutes later. (The alarm outputs relay always in closed state without warning, and will be cut off when inspecting invasion or warning signals).

**b. Remote ( keyboard ) Defense Layout** Through keyboard setting the alarm state, details see the control equipment described.

## 6. Dome Camera Bracket Installation

Notice :

- ☞ This installation should be made by a qualified service person and should conform to all local codes.
- ☞ The detailed wiring refers to the operational instructions and installation notes.

- ☞ The lower dome cover belongs to high-grade optical products. Don't touch by hands directly to avoid sharp and affect the quality of images.
- ☞ The lower dome cover should be cleaned regularly to ensure imaging clearly. Cleaning must be careful only holding the round circle by hand avoids directing contact the lower cover. The acidity sweat mark by fingers may corrode the surface plating. The lower cover hit by hard object may lead to the camera imaging vague and effect imaging quality. Please use sufficient soft dry cloth or other similar substitutes wipe the surface inside and outside. If very dirty use neutral detergents. Any high-grade cleaning products can be used for cleaning the lower cover.

#### 1) Installation Requirements:

- ☞ This Installation should be made by professional staff and should comply with the corresponding requirements to avoid failures. Identification of all accessories supplied with the camera is complete or not. Determine if the location and installation method meet the requirements of the dome camera.

#### 2) Dome Camera Bracket (Wall) Installation

Notice Check out the installation place. It should be strong enough to support more than 5 times the total product weight including the speed dome camera, the bracket and the base, to avoid images shaking caused by instability installation.

- a. Using the wall bracket as template, mark center space of holes in wall.
- b. Using an impact electric drill drilling 4 holes in the mounting surface and then install metal expansion M8 screws.
- c. Make power cable, communication cable and video cable through the holes of bracket and leave sufficient cables length for wiring.
- d. Using 4 pieces of M8 nut and spacers to fix bracket firmly in the wall.

If the camera holder had been installed within the housing, following five items as a reference only:

- e. Remove Camera Holder Remove the dome camera from package, first unscrew the two M5 screws in the camera holder unscrew 3-5 circles and remove the camera holder.
- f. Housing Installation Insert the cables to the housing, and use three M5 screws fasten the housing to the bracket.
- g. Refer to the [Wiring Diagram]; make the BNC video cable of dome camera to connect with the video

Cable layout completed. Make RS485 cable of the dome camera to connect with RS485 cable layout completed. The supply voltage is DC12V , please use the adaptor AC220V-DC12V supplied with the machine.

- h. Inspecting polarity of plug & socket, to ensure wiring correctly and setup the switch code of dome camera.
  - i. Camera Holder Installation Hold the camera holder, make the two holes of camera holder aim at the two M5 screws in the base. Circulate the camera holder in up time direction, make the two M5 screws enter into the end of holes. Fasten the two screws and make the camera holder fixed in the housing.
- 3) Electrify
- Automatic Inspection The dome camera make pan & tilt rotation and inspecting camera lens, pan & tilt of the electrical and mechanical structure. Then back to the #1 preset positions automatically the dome camera stopped means prepared to accept control.
- 4) Lower Cover Installation
- a. Use soft cloth remove the dust and smear on the transparent cover to prevent scratching.
  - b. Make three screw holes of lower cover aim at the screw holes in the housing, and use three M3 screws fasten them.

## **7. Dome Camera In-Ceiling Installation**

Notice Installation location must choose a solid ceiling without surface off phenomenon. Installation site must be able to withstand more than 5 times weight of the dome camera to avoid images shaking caused by instability installation.

1. Opening Hole Measure the actual size of in-ceiling housing. Select the center of ceiling and marking a round based on the actual size. Then using shaped device opening a hole in the ceiling.
2. Housing Installation :
  - a) Remove housing from the package and adjust the compressed spring bigger than the actual thickness of ceiling.
  - b) Insert the cables to the housing.
  - c) Make the three compressed springs stick to the outside surface of round drum. Install the housing into the hole of ceiling and make the flange surface cling the ceiling surface closely.
  - d) Use screwdriver circulates the long bolts of compressed spring and makes the compressed spring bear down on the ceiling. The flange surface cling the ceiling surface closely.
- 3) Camera Holder Installation: If the camera holder had been installed within the dome cover, following four items as a reference only:
  - a) Remove Camera Holder Remove the dome camera from package, first unscrew the two M5 screws in the camera holder unscrew 3-5 circles and remove the camera holder.
  - b) Refer to the [Wiring Diagram]; make the BNC video cable of dome

camera to connect with the video cable layout completed. Make RS485 cable of the dome camera to connect with RS485 cable layout completed. The supply voltage is DC12V , please use the adaptor AC220V-DC12V supplied with the machine.

- c) Inspecting polarity of plug & socket, to ensure wiring correctly and setup the switch code of dome camera.
- d) Camera Holder Installation Hold the camera holder, make the two holes of camera holder aim at the two M5 screws in the base. Circulate the camera holder in up time direction, make the two M5 screws enter into the end of holes. Fasten the two screws and make the camera holder fixed in the housing.

#### 4、Electrify

Automatic Inspection The dome camera make pan & tilt rotation and inspecting camera lens, pan & tilt of the electrical and mechanical structure. Then back to the #1 preset positions automatically the dome camera stopped means prepared to accept control.

#### 5、Lower Cover Installation

- a) Use soft cloth removes the dust and smear on the transparent cover to prevent scratching.
- b) Make the lower cover aim at the flange surface and circulate in up time direction cling to the flange surface closely.

## 8、 Basic Function & Operation

The high speed dome camera can be controlled by keyboard, matrix and DVR. The user can achieve the following functions according to the instruction manual of controlling equipments:

- 1) Switch on the machine or restoration, high-speed dome camera rotate to #1 preset position (guard position).
- 2) Manual control pan and tilt rotation and the speed can be adjusted.
- 3) Manual control zoom rate and focal length of lens.
- 4) Preset Positions Setting : 1-30 & 59-128 total 100 preset positions can be set up or call.  
#31--#38 are eight scanning tour groups of dome camera memorized.  
#39--#54 are specific command of speed dome camera.
- 5) Delete Preset Positions:
  - ☐ Needless preset positions can be covered by new preset positions, and the new preset positions may participate the scanning tour groups.
  - ☐ Needless preset positions also can be deleted, and the deleted preset positions won't participate the scanning tour groups.
- 6) Manual Call Preset Positions: Each operation may call one preset position.
- 7) Scanning Tour Groups Setting : #31—#38 are eight scanning tour groups of dome camera memorized, which not used as a signal preset position. Each group composed of 2-64 scanning points and the scanning points are preset positions which setup already. Each group may connect 64 preset positions at most. The user can setup at any time and call any group from the eight groups.

For example , #31 scanning tour group setup like as below:

- a、 #31 Preset Positions Setup--- enter into #31 scanning tour group

- b、 Call #2 Preset Position
- c、 Call #3 Preset Position
- d、 Call #5 Preset Position
- e、 Call #7 Preset Position
- f、 Call #8 Preset Position
- g、 Call #9 Preset Position
- h、 Call #31 Preset Position --- End #31 scanning tour group setup, save and run scanning tour group.

Then, these 6 preset positions include #2, #3, #5, #7, #8, #9 are scanning tour group of #3. And other scanning tour groups of #32—#38 setup like as this one.

8) Call Scanning Tour Groups the high-speed dome camera may call multi-preset positions in turn, and the interval time can be adjusted. Go round and begin again until the user stop the tour groups. The user may call any group of the scanning tour groups from #31 to #38.

9) Stop Scanning Tour Groups Manual control pan & tilt rotation, and then the high speed dome camera may stop running the scanning tour groups.

10) Specific Command of High Speed Dome Camera ;

Call #39-#54 preset positions are specific command of high speed dome camera, not used as a single preset position:

- [39]+ [CALL] ----- Start pan scanning automatically
- [40]+ [CALL] ----- Call preset positions or pan scanning with low speed
- [41]+ [CALL] ----- Call preset positions or pan scanning with middle speed
- [42]+ [CALL] ----- Call preset positions or pan scanning with high speed
- [43]+ [CALL] ----- The period is 3 seconds for calling preset positions of scanning tour group
- [44]+ [CALL] ----- The period is 5 seconds for calling preset positions of scanning tour group
- [45]+ [CALL] ----- The period is 7 seconds for calling preset positions of scanning tour group
- [46]+ [CALL] ----- Enter/Escape camera menu, keyboard operation "ZOOM" & "FOCUS" will change menu option and setting
- [47]+ [CALL] ----- Screen Character ON/OFF switch able
- [48]+ [CALL] ----- Color/B-W switch able
- [49]+ [CALL] ----- Pan & tilt speed change along with zoom change
- [50]+ [CALL] ----- Pan & tilt speed don't change along with zoom change
- [51]+ [CALL] ----- Display camera model
- [52]+ [CALL] ----- Don't display camera model
- [53]+ [CALL] ----- Display ZOOM change icon
- [54]+ [CALL] ----- Don't display ZOOM change icon

**Notice the numerical value of preset positions maybe minus "1" due to different controlling equipments or communication protocol.**

**Example Call preset # 54 for Don't display Zoom change icon will be enter as #53 and call button.**

## 9 . Security and Guidelines

- 1) Please read this manual carefully before using the camera. This installation should be made by a qualified service person and should conform to all local codes.
- 2) Please refer to the Manual for all operations.
- 3) Please do not place camera on unstable desktop or rack.
- 4) Please do not include any foreign object or fluid material into machine, to avoid damage.
- 5) Electrical wiring must comply with the safety standards and use the power adaptor supplied with the dome camera. The RS-485 communication and video signal adopt TVS grade lightning protecting technology. Sufficient prevent lightning strike below 500W and surge etc. Keep enough distance from RS-485 & video signal to high voltage equipment or cables in transmitting. If need, please adopt proper measures to prevent lightning strike and surge.
- 6) No matter in use or not in use, should not make the camera aim at sun or other powerful light and reflector. Or probably create lasting breakdown of camera CCD.

Don't make any repairs when the machine has failure. Firstly, check failure refer to the instruction manual or check failure by professional staff. Only staff authorized by our company can repair the machine.

#### 10. Address Code Correspondence Tables

8-Digital Code	Camera ID	8-Digital Code	Camera ID	8-Digital Code	Camera ID	8-Digital Code	Camera ID
00000000	1	00100000	33	01000000	65	01100000	97
00000001	2	00100001	34	01000001	66	01100001	98
00000010	3	00100010	35	01000010	67	01100010	99
00000011	4	00100011	36	01000011	68	01100011	100
00000100	5	00100100	37	01000100	69	01100100	101
00000101	6	00100101	38	01000101	70	01100101	102
00000110	7	00100110	39	01000110	71	01100110	103
00000111	8	00100111	40	01000111	72	01100111	104
00001000	9	00101000	41	01001000	73	01101000	105
00001001	10	00101001	42	01001001	74	01101001	106
00001010	11	00101010	43	01001010	75	01101010	107
00001011	12	00101011	44	01001011	76	01101011	108
00001100	13	00101100	45	01001100	77	01101100	109
00001101	14	00101101	46	01001101	78	01101101	110
00001110	15	00101110	47	01001110	79	01101110	111
00001111	16	00101111	48	01001111	80	01101111	112
00010000	17	00110000	49	01010000	81	01110000	113
00010001	18	00110001	50	01010001	82	01110001	114
00010010	19	00110010	51	01010010	83	01110010	115
00010011	20	00110011	52	01010011	84	01110011	116
00010100	21	00110100	53	01010100	85	01110100	117
00010101	22	00110101	54	01010101	86	01110101	118
00010110	23	00110110	55	01010110	87	01110110	119
00010111	24	00110111	56	01010111	88	01110111	120
00011000	25	00111000	57	01011000	89	01111000	121
00011001	26	00111001	58	01011001	90	01111001	122
00011010	27	00111010	59	01011010	91	01111010	123
00011011	28	00111011	60	01011011	92	01111011	124
00011100	29	00111100	61	01011100	93	01111100	125
00011101	30	00111101	62	01011101	94	01111101	126
00011110	31	00111110	63	01011110	95	01111110	127
00011111	32	00111111	64	01011111	96	01111111	128

Address Code Correspondence Tables Continue )

8-DigitalCode	Camera ID	8-DigitalCode	Camera ID	8-DigitalCode	Camera ID	8-DigitalCode	Camera ID
10000000	129	10100000	161	11000000	193	11100000	225
10000001	130	10100001	162	11000001	194	11100001	226
10000010	131	10100010	163	11000010	195	11100010	227
10000011	132	10100011	164	11000011	196	11100011	228
10000100	133	10100100	165	11000100	197	11100100	229
10000101	134	10100101	166	11000101	198	11100101	230
10000110	135	10100110	167	11000110	199	11100110	231
10000111	136	10100111	168	11000111	200	11100111	232
10001000	137	10101000	169	11001000	201	11101000	233
10001001	138	10101001	170	11001001	202	11101001	234
10001010	139	10101010	171	11001010	203	11101010	235
10001011	140	10101011	172	11001011	204	11101011	236
10001100	141	10101100	173	11001100	205	11101100	237
10001101	142	10101101	174	11001101	206	11101101	238
10001110	143	10101110	175	11001110	207	11101110	239
10001111	144	10101111	176	11001111	208	11101111	240
10010000	145	10110000	177	11010000	209	11110000	241
10010001	146	10110001	178	11010001	210	11110001	242
10010010	147	10110010	179	11010010	211	11110010	243
10010011	148	10110011	180	11010011	212	11110011	244
10010100	149	10110100	181	11010100	213	11110100	245
10010101	150	10110101	182	11010101	214	11110101	246
10010110	151	10110110	183	11010110	215	11110110	247
10010111	152	10110111	184	11010111	216	11110111	248
10011000	153	10111000	185	11011000	217	11111000	249
10011001	154	10111001	186	11011001	218	11111001	250
10011010	155	10111010	187	11011010	219	11111010	251
10011011	156	10111011	188	11011011	220	11111011	252
10011100	157	10111100	189	11011100	221	11111100	253
10011101	158	10111101	190	11011101	222	11111101	254
10011110	159	10111110	191	11011110	223	11111110	255

10011111	160	10111111	192	11011111	224	11111111	
----------	-----	----------	-----	----------	-----	----------	--

## **Factory rewires**

- 1- Power connector Black cable with female plug for 12 VDC.
- 2- RS585 cable for control data White to RS485 B or (-) Brown to RS485 A or (+).  
**Beware do not connect power voltage to this cable; it will damage the controller inside.**
- 3- BNC connector for video connection.
- 4- Input and out control cable. (**do not apply voltage power to theses wires**)
  - a- Pair of green wires for Input #1
  - b- Pair of Blue wires for Input #2
  - c- Pair of Brown wires for Input #3
  - d- Pair of Orange wires for Input #4
  - e- Pair of Red and Black wires for Output #1

### **Camera RS485 control set as**

**Protocol = Pelco D**

**Camera ID # 1**

**Baud rate 2400.**

To change these setting please refer to page #3

Any question please calls 214-660-0900 or email us at [support@311cctv.com](mailto:support@311cctv.com)

Thank you for your business.